

# STRAIN PROFILE AND PIEZOELECTRIC PERFORMANCE OF PIEZOCOMPOSITES WITH 2-2 AND 1-3 CONNECTIVITIES

Q. M. Zhang, Wnewu Cao, H. Wang, and L. E. Cross  
Materials Research Laboratory, The Pennsylvania State University  
University Park, PA 16802

**Abstract:** The piezoelectric performance of 1-3 type composite depends critically on the stress transfer between the two constituents phases. This paper presents the results of our recent investigation on the elastic and piezoelectric behaviors of composites with 2-2 and 1-3 connectivities. By taking into account the nonuniform strain profiles in the constituent phases, the theoretical model presented can quantitatively predict the performance of these composites. Theoretical predictions agree quantitatively with the experimental results.

### Introduction

The quantitative study of the performance of piezoceramic-polymer composites is an interesting and challenging problem. In the past, a great deal of studies have been devoted to this subject.<sup>1-3</sup> Nevertheless, most of these studies are based on the effective medium theory, where the material properties in each constituent phase are assumed to be uniform, and the effective material parameters of a composite are calculated using either the parallel model (Voigt averaging) or series model (Reuss averaging). Although these studies provided general guidelines in predicting the composite properties, the quantitative predictions of the effective material parameters deviate from the experimental observations in most cases.

In this paper, we will present the results of our recent study on piezoceramic-polymer composites with 2-2 and 1-3 type connectivity.<sup>4-6</sup> Since the most important factor of a composite structure is the stress transfer between the two constituent phases, the key to establish a working model for the composites is to understand how this stress transfer is realized. Illustrated in figure 1 is a 2-2 composite structure in which the ceramic plates and polymer are arranged parallel with each other. When subjected to a uniaxial stress, the composite will deform as illustrated by the dashed lines in figure 1(b). For comparison, we have also plotted in the same figure the deformation profile assuming no elastic coupling between the two constituent phases. The effectiveness of the stress transfer between the two phases depends on how much the strain in the polymer phase differs in the two situations [the area between the dash-dotted line and the dashed line in figure 1(b)]. This is determined by the elastic properties of the constituent phases and geometric factors of the composite. Clearly, the stress transfer in the composite is through the shear force and the strain in both phases is not uniform. When the strain is uniform in the composite, there is a maximum stress transfer between the two phases. This is the base for the isostrain model. However, to achieve that situation,

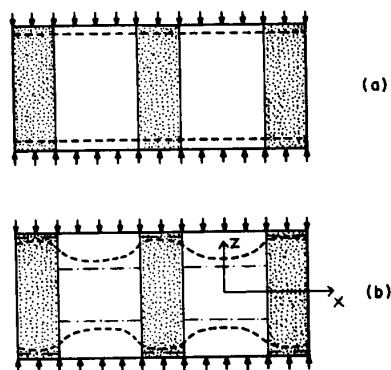

**Figure 1:** Schematic drawing of the 2-2 composite: (a) strain profile (dashed line) of the composite from the isostrain model when subjected to a uniaxial stress; (b) real strain profile (dashed line).

the shear modulus of the polymer phase needs to be infinity, which is not practical. This explains why the theoretical calculations based on the isostrain model always overestimate the piezoelectric response of composites. Shown in figure 2 is the strain profile for a 1-3 composite manufactured by Fiber Materials, Inc.. The strain profile was measured by the double beam laser interferometer. Clearly, the strain in the polymer phase is much smaller than that expected from the isostrain model. The major advance of our model is to take into account this nonuniformity of the strain profile in the constituent phases explicitly. Therefore, this model can make quantitative predictions on the dependence of the effective material properties of a composite on the properties of its constituent phases and the sample geometric factors.

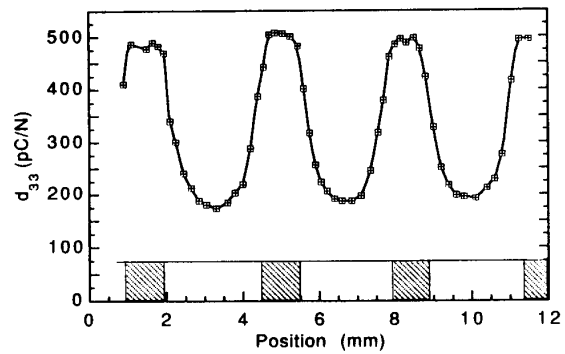

**Figure 2:** Strain profile for a 1-3 composite measured by the double beam laser interferometer. Hatched regions are PZT rods

### The strain profile in 2-2 composites

The cross section of a 2-2 lamellar ceramic-polymer composite is shown in figure 3, where  $a$  and  $d$  are the dimensions of the ceramic plate and the polymer respectively in the  $x$ -direction, and  $L$  is the thickness of the composite in the  $z$ -direction. The dimension of the composite in the  $y$ -direction is much larger than  $L$ ,  $a$  and  $d$ .

Under a uniaxial stress  $T_3$ , both the polymer and the ceramic are either stretched or compressed depending on the sign of  $T_3$ . From symmetry consideration, the  $z=0$  plane (mirror plane) does not move at all in the  $z$ -direction. In the near static case, one can assume the strain to be uniform in the  $z$ -direction for any given  $x$ . Taking a segment as shown in figure 3 with unit length in the  $y$ -direction ( $h=1$ ), the total shear force in the  $z$ -direction  $f_s$  is

$$f_s = (L/4) \mu u_{xx}(x, L/2) dx$$

where  $u(x, L/2)$  is the displacement profile at the top surface of the polymer,  $\mu$  is the shear modulus of the polymer. In the  $x$ -direction the composite can move freely and the stress component in this direction is therefore zero. In the  $y$ -direction, the polymer is bounded by the ceramic plates and the total stress in this direction is lumped into  $T_2$  since we are not interested in the details of this stress component. From these conditions, one can write down the constitutive relations for this elastic body:

$$\frac{2 u(x, L/2)}{L} = s_{33} \left( \frac{L}{4} \mu u_{xx}(x, L/2) + T_3 \right) + s_{32} T_2 \quad (1a)$$

$$S_2 = s_{22} T_2 + s_{32} \left( \frac{\mu L}{4} u_{xx}(x, L/2) + T_3 \right) \quad (1b)$$

where  $S_2$  is the  $y$ -component of the strain in the polymer phase,  $s_{ij}$  is the elastic compliance. For the polymer, one has the relations:  $s_{22} = s_{33}$  and  $s_{32}/s_{33} = -\sigma$ , where  $\sigma$  is the Poisson's ratio. For a 2-2

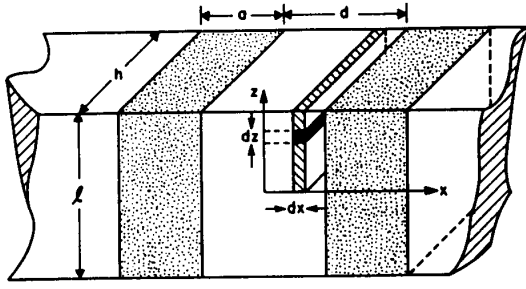

Figure 3: A section of 2-2 composite for our analysis.

composite with its y-dimension much larger than L, a and d,  $S_2$  is practically a constant and is independent of x. That is, the strain in this direction can be modelled by the isostrain approximation. Combining eqs (1a) and (1b) to eliminate  $T_2$  yields

$$\frac{2u(x, L/2)}{L} = s_{33}(1-\sigma^2) \frac{L}{4} \mu u_{xx}(x, L/2) + s_{33}(1-\sigma^2) T_3 - \sigma S_2 \quad (2)$$

If one neglect the stress effect in the y-direction, eq. (1) will be reduced to

$$\frac{2u(x, L/2)}{L} = s_{33} \frac{L}{4} \mu u_{xx}(x, L/2) + s_{33} T_3 \quad (3)$$

Hence, the effect of the y-direction stress on the strain in the z-direction is to modify the elastic compliance  $s_{33}$  to  $s_{33}(1-\sigma^2)$  and to add an additional constant term (Poisson's ratio effect) in the equation. It does not affect the functional form of the equation. Considering the fact that both  $T_3$  and  $S_2$  are constants, we can make variable substitution:  $v=u+(L/2)(\sigma s_2 - s_{33}(1-\sigma^2) T_3)$  and equation (2) becomes

$$\frac{2v(x, L/2)}{L} = s_{33}(1-\sigma^2) \frac{L}{4} \mu v_{xx}(x, L/2) \quad (4)$$

Therefore, the strain profile in the polymer phase between the two neighboring ceramic plates is

$$\frac{2u}{L} = A \cosh\left(2 \frac{x}{L} \sqrt{2Y/(\mu(1-\sigma^2))}\right) + \frac{T_3}{Y} - \sigma S_2 \quad (5)$$

where A is the integration constant,  $Y=1/s_{33}$  is the Young's modulus of the polymer phase.  $x=0$  is at the center of the polymer filling. A can be determined from the boundary condition:  $A=$

$(2u_0/L - T_3/Y + \sigma S_2) / \cosh\left(\frac{d}{L} \sqrt{2Y/(\mu(1-\sigma^2))}\right)$ , where  $2u_0/L$  is the strain in the polymer-ceramic interface. For the situation when there is only one ceramic phase in the composite, the longitudinal strain of the polymer phase is

$$2u/L = B \exp\left(-\frac{(x-a/2)d}{L} \sqrt{2Y/(\mu(1-\sigma^2))}\right) + \frac{T_3}{Y} - \sigma S_2 \quad (x > a/2)$$

and

$$2u/L = B \exp\left(\frac{(x-a/2)d}{L} \sqrt{2Y/(\mu(1-\sigma^2))}\right) + \frac{T_3}{Y} - \sigma S_2 \quad (x < -a/2)$$

where  $x=0$  is set at the center of the ceramic plate.

To compare with the theory, several 2-2 composites were made using PZT-5A plates embedded in spurs epoxy matrix. The longitudinal strain  $S_3=2u/L$  of the sample was mapped out along a path parallel to the x-axis (refer to figure 1) using the double beam laser interferometer. Presented in figure 4 is the profile taken from one of these scans. The solid line in the figure is the fitting using eq. (5) for the polymer regions between the PZT plates and eq. (6) at the two edges of the sample. Clearly, the theoretical curve describes the data quite well. From fitting the data, one can obtain the value of  $Y/(\mu(1-\sigma^2))=3.35$ . For an isotropic medium, we have the relationship  $Y/\mu=2(1-\sigma)$ . Therefore, from the value of  $Y/(\mu(1-\sigma^2))=3.35$ , we can derive  $\sigma=0.4$ , which is a reasonable

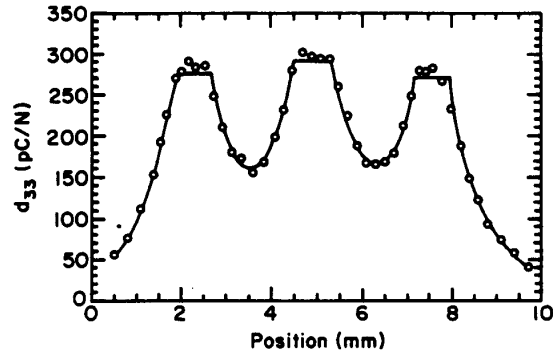

Figure 4: Comparison between the experimentally measured strain profile (dots in the figure) of a 2-2 composite and the theoretical curves (solid lines).

value for the spurs epoxy used.

#### Single rod 1-3 composite

Although the basic stress transfer mechanism between the two constituent phases in a 1-3 type composite is similar to that in the 2-2 type, the problem of solving the strain profile in a regular 1-3 composite is more involved and may be calculated numerically. Here we will only treat one special case, a single rod 1-3 composite subjected to a hydrostatic pressure, to show quantitatively how various parameters affect the performance of a 1-3 composite. The single rod composite is schematically drawn in figure 5, where a cylindrical coordinate system is used. This configuration is a reasonable approximation to the composite with triangularly arranged ceramic rods (for which the unit cell has hexagonal symmetry) and at low ceramic content, the results here could even be used for composites with other rod arrangements.<sup>6</sup>

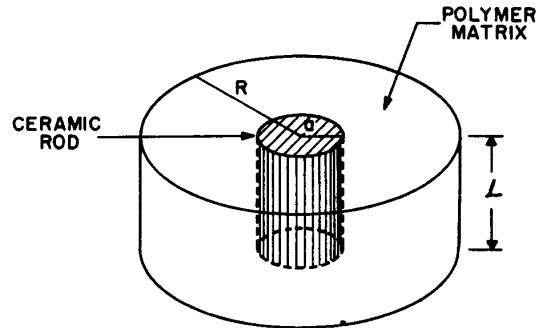

Figure 5: Schematic drawing of a single rod 1-3 composite.

Similar to the 2-2 composite situation, the force equilibrium condition for the polymer phase can be written in the following form<sup>6</sup>

$$\frac{\mu L}{4} \left( u_{rr}(r, L/2) + \frac{u_r(r, L/2)}{r} \right) - (1-2\sigma) p = \frac{2Y}{L} u(r, L/2) \quad (7)$$

where the meaning of each quantity is similar to that in the preceding section and p is the hydrostatic pressure. One can write down similar equation for the strain profile in the ceramic rod. The strain profile for the polymer phase is therefore given by

$$2u/L = A K_0(r/\xi) + B I_0(r/\xi) - (1-2\sigma) p/Y \quad (8)$$

where  $K_0(p)$  and  $I_0(p)$  are zeroth order modified Bessel functions. A and B can be determined from the boundary conditions. From the

strain profile, one can calculate the stress transfer between the two constituent phases and hence the effective piezoelectric hydrostatic strain constant  $d_h$ :

$$d_h = V_c (\gamma_h d_{33}^c + 2 d_{31}^c) \quad (9)$$

$$\gamma_h = 1 + \frac{\frac{L}{a} I_1(\rho_R^c) [I_1(\rho_R) K_1(\rho_a) - I_1(\rho_a) K_1(\rho_R)] [(1-2\sigma^c)/Y - (1-2\sigma^c) s_{33}]}{\sqrt{\frac{2s_{33}}{c_{44}} I_0(\rho_a^c) [I_1(\rho_R) K_1(\rho_a) - I_1(\rho_a) K_1(\rho_R)]} + \sqrt{\frac{2}{Y\mu} I_1(\rho_a^c) [I_1(\rho_R) K_0(\rho_a) + I_0(\rho_a) K_1(\rho_R)]}} \quad (10)$$

where  $s_{33}$  and  $c_{44}$  are the elastic compliance and the shear constant of the ceramic,  $\sigma^c$  is the Poisson's ratio of the ceramic,

$$\rho_r = (2\tau/L) \sqrt{\frac{2Y}{\mu}} \quad \text{and} \quad \rho_r^c = (2\tau/L) \sqrt{\frac{2}{s_{33}c_{44}}} \quad \text{One can see that}$$

the stress amplification factor depends on the elastic properties of the constituent phases and most importantly, on the aspect ratio of the ceramic rod. Plotted in figure 6 is the calculated results for  $d_h$  from eq. (9) for several different aspect ratios for a PZT5H-Spurs epoxy composite. The input data can be found in reference 6. Clearly, aspect ratio of the PZT rod is an important parameter in determining the piezoelectric performance of 1-3 composites.

Shown in figure 7 is the comparison between the experimentally measured  $d_h$  for a 1-3 composite with 1% PZT volume content in spurs epoxy matrix and that calculated from equation (9). The parameters used in the calculation are listed in reference 6, and  $d_{33}$  and  $d_{31}$  were treated as fitting parameters. The agreement between the experimental result and theoretical calculation is satisfactory.

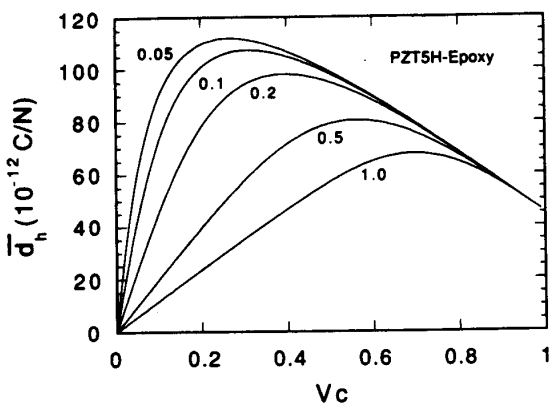

Figure 6: The hydrostatic piezoelectric constant  $d_h$ , as a function of the ceramic content at the aspect ratio of  $a/L=0.05, 0.1, 0.2, 0.5$  and  $1.0$  for a single rod PZT5H-Epoxy 1-3 composite.

#### Conclusions

In general, the response of the constituent phases of a composite to an external field is not uniform spatially. By taking into account the nonuniform strain profiles in the constituent phases, the theoretical model presented in this paper can quantitatively predict the performance of these composites. Theoretical predictions agree quantitatively with the experimental results.

where  $V_c$  is the volume content of the ceramic in the composite,  $d_{33}^c$  and  $d_{31}^c$  are the piezoelectric constants of the ceramic phase, and  $\gamma_h$  is the stress amplification factor:<sup>6</sup>

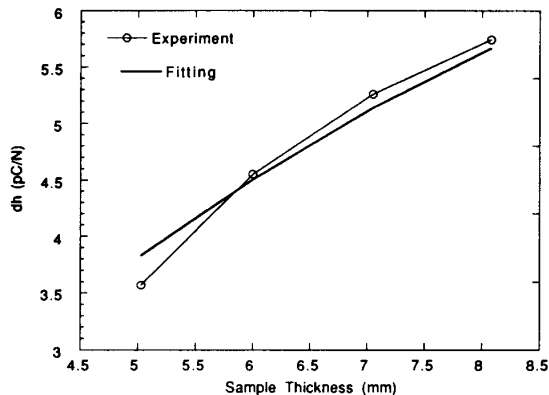

Figure 7: Thickness dependence of  $d_h$  for a 1-3 composite and the comparison with the theoretical prediction. The radius of the PZT rod is  $0.405$  mm.

#### References

- [1] Newnham, R. E., D. P. Skinner, and L. E. Cross, "Connectivity and Piezoelectric-Pyroelectric Composites," *Materials Res. Bull.*, vol 13, pp. 525-536, 1978.
- [2] Gururaja, T. R., A. Safari, R. E. Newnham, and L. E. Cross, "Piezoelectric Ceramic-Polymer Composites for Transducer Applications," in *Electronic Ceramics*, ed. L. M. Levinson, pp. 92-128, New York: Marcel Dekker, 1987.
- [3] Smith, W. A., B. A. Auld, "Modeling 1-3 Composite Piezoelectrics: Thickness-Mode Oscillations," *IEEE Trans. on Ultrasonics, Ferro., and Freq. Control*, vol 38, pp. 40-47, 1991.
- [4] Wenwu Cao, Q.M. Zhang, and L. E. Cross, "Theoretical Study on the Static Performance of Piezoelectric Ceramic-Polymer Composites with 2-2 Connectivity," *IEEE Trans. Ultrasonics, Ferro., and Freq. Control*, in press, 1992.
- [5] Q. M. Zhang, Wenwu Cao, H. Wang, and L. E. Cross, "Characterization of the Performance of 1-3 Type Piezocomposites for Low Frequency Applications," submitted to *J. Appl. Phys.*, 1992.
- [6] Wenwu Cao, Q. M. Zhang, and L. E. Cross, "Theoretical Study on the Performance of Piezoelectric Ceramic-Polymer Composites with 1-3 Connectivity," accepted by *J. Appl. Phys.*, 1992.